

KENWORTH CURVED WINDOW DROPPED VISOR INSTALLATION INSTRUCTIONS

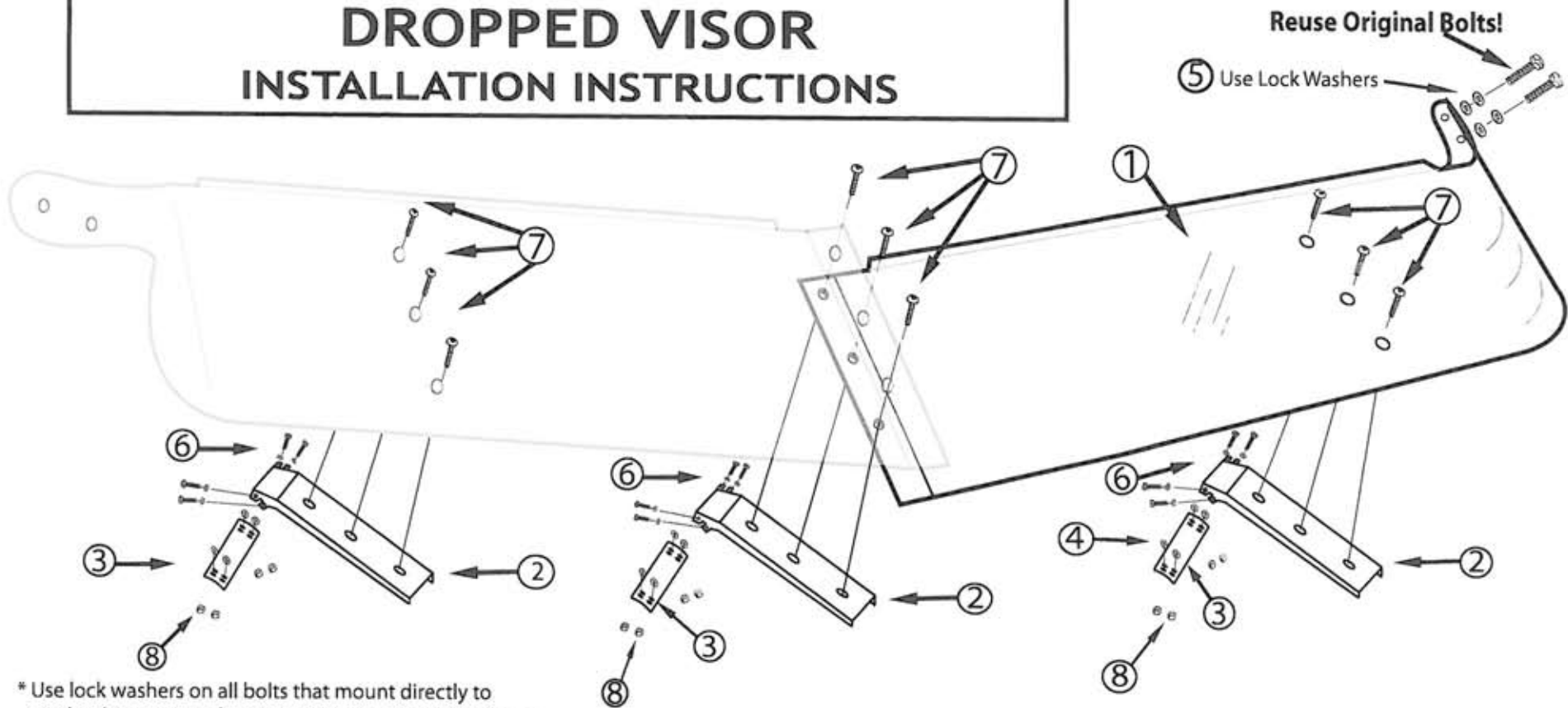

* Use lock washers on all bolts that mount directly to truck cab to prevent loosening due to normal vibrations.

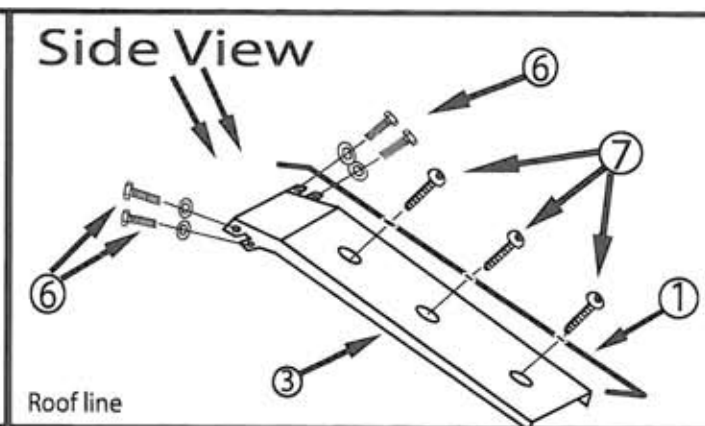
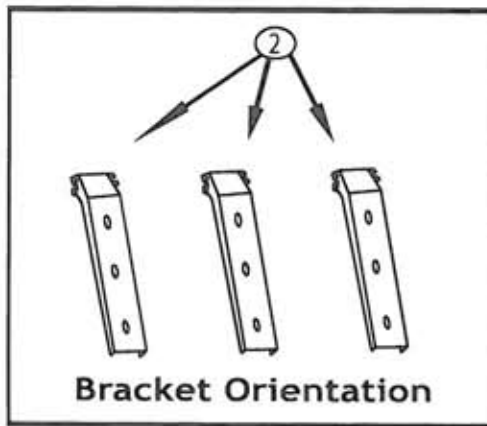

Inspected by:		Date	REVISION 3/12
Item	QTY	Description	Size
①	2	Visor body Halve	13.5" x 35"
②	3	Brackets (ds,ps,ctr) (VK130003-2)	11-3/4" x 1-7/8"
③	3	Internal Support Plates	6 x 2 3/4"
④	33	Washers	1/4"
⑤	4	Lock Washers	1/4"
⑥	12	Hex Head Bolt	1/4-20 x 3/4"
⑦	9	Truss Head Machine Screw	1/4-20 x 1/4"
⑧	21	Nylock Nuts	1/4-20

KENWORTH 2007 w900L
DROPPED SUN VISOR INSTRUCTIONS
Read Entire Instruction Sheet before Beginning

Steps:

1. Unpack the carton and make sure all parts are in the box.
2. Remove your current visor:
 - a. Note: You will need to reuse the bolts which go into the cab of the truck.
3. Grind off the heads of the Huck bolts
 - a. Hold the existing brackets in place and take your time carefully grinding the huck bolt heads off. If you grind too fast or too hard you will damage the paint around the head. It is recommended that you grind a little bit at a time.
4. Mount two mounting brackets in place of the old brackets. With one person holding the bracket on the outside and one person installing the inner support plates and hand tighten the nuts.
5. Install driver side visor with one bolt in the end of the cab and one bolt through the bracket. Repeat for the passenger side visor.
6. Mount the center bracket through the center holes in the two visor halves and align center bracket.
 - a. Now with the visor aligned mark the holes in the center mounting bracket and extra hole at the end of each side of the visor using this as a template.
7. Remove the visor
8. Center punch where the holes are to be drilled.
 - a. Drill center mounting bracket holes with a 1/4" drill bit.
 - b. Drill the holes at the end of the visor using 13/32" drill bit.
9. Install center mounting bracket (step 4)
10. Install fastener in cab with assembly supplied.
11. Install visor (step 5) and all remaining bolts and align.
12. Remove pvc coating and tighten all bolts and screws. We recommend loctite or silicone to prevent loosening from over the road use.