

**LEAVE YOUR MARK
ON THE WORLD
NOT YOUR FLOOR.**

MINIMIZER FLOOR MATS

- **TESTED AND TORTURED™** •
- DAILY BY TRUCKERS FOR TRUCKERS

FAILURE TO CORRECTLY INSTALL AND USE YOUR MINIMIZER FLOOR MATS ACCORDING TO THE INSTRUCTIONS ABOVE COULD PREVENT PROPER FUNCTIONING OF THE VEHICLE'S PEDALS, POTENTIALLY RESULTING IN LOSS OF CONTROL OF THE VEHICLE AND SERIOUS INJURY OR DEATH

WARRANTY

Minimizer Floor Mats are backed by a Lifetime Manufacturer's Warranty and are guaranteed against flaws due to faulty materials and/or unintended production variations. This warranty extends only to the original purchaser and excludes damage caused by abnormal use or conditions, including but not limited to extreme abrasive conditions and/or excessive exposure to chemicals such as bleach, gasoline and other fuels.



MINIMIZER PRODUCTS
• **TESTED AND TORTURED™** •
DAILY BY TRUCKERS FOR TRUCKERS

Since inventing the poly fender back in 1984, Minimizer™ has grown from a one-product company into the leader in heavy duty aftermarket parts. Boasting an array of Tested & Tortured™ products, from Custom Molded Floor Mats to the Long Haul Series™ Truck Seat and Mattress, our goal is to #RespectTheDriver. We do this by stamping premium products with our standard Lifetime Warranty. The Minimizer logo means it is built to last, and sends a very clear message to your customers and competitors that you're well-equipped to handle even the harshest conditions in one of the toughest industries.



500 Minimizer Way, Blooming Prairie, MN 55917
800.248.3855 • Fax: 507.583.7540
www.minimizer.com

IMPORTANT SAFETY INFORMATION

READ BEFORE INSTALLING OR USING MINIMIZER FLOOR MATS

Floor Mat Kit #100864 is compatible with the following models equipped with a manual transmission:

- Freightliner Coronado CC122 – 2010-2016*
- Freightliner Coronado CC132 – 2010-2016*
- Freightliner 122SD – 2013-2019*

Floor Mat Kit #100865 is compatible with the following models equipped with an automatic transmission:

- Freightliner Coronado CC122 – 2010-2016*
- Freightliner Coronado CC132 – 2010-2016*
- Freightliner 122SD – 2013-2019*

Notes:

- * Compatibility with Coronado glider kit trucks is dependent on interior type.
 - Minimizer Floor Mat Kit 100864 and 100865 are compatible with Coronado glider kit trucks equipped with a second generation interior.
 - For Coronado glider kits with first generation interior use Minimizer floor mat kit FKFR3L3MB or FKFR3L3AB.
- Driver, passenger, and center floor mats are designed to fit the most common OEM seat bases. In some cases hand trimming along raised ribs is required.

Safety Instructions for Installation

- Use only with the specified vehicle make, model and year.
- Do not install on top of other floor mats.
- Install each floor mat with the Minimizer logo facing up.
- Use each floor mat only in its proper location in the vehicle.
- Install and use a retention hook for the driver side floor mat.
- Make sure that the floor mats fit properly in your vehicle floor space.
- Do not place additional floor mats on top of the Minimizer floor mats.
- Carefully follow each of the Installation Instructions for Minimizer Floor Mats on the following pages.

Safety Instructions for Vehicle Operation

- Before starting or operating the vehicle, verify that the Minimizer floor mats are installed correctly, that the driver side mat is secured by a retention hook, and that the driver side mat does not interfere with the accelerator, brake, or clutch pedal.
- Make sure there are no loose objects in the vehicle that could possibly interfere with the operation of the accelerator, brake, or clutch pedal.
- If your Minimizer floor mat becomes loose, stop the vehicle at the next safe location. Re-install the floor mat properly and securely. If that is not possible, remove the floor mat and place it in a location where it will not interfere with safe operation of the vehicle.
- Inform all drivers of these warnings before allowing them to operate a vehicle equipped with Minimizer floor mats.

If you have questions about these instructions or proper installation of your Minimizer floor mats, please contact Minimizer at (800) 248-3855.



Item # 104166

February 2019

Minimizer floor mats are specifically designed for certain vehicles and may be used safely only with those vehicles. **VERIFY THAT THE MAKE, MODEL, AND YEAR OF THE VEHICLE IN WHICH YOU ARE INSTALLING THE FLOOR MATS IS IDENTIFIED ON PAGE 1 AS BEING COMPATIBLE WITH THE MINIMIZER FLOOR MATS YOU HAVE SELECTED.**

FREIGHTLINER FLOOR MAT KIT SPECIFICATIONS:

Figure 1 - Floor Mat Kit # 100864



• Contents of floor mat kit 100864 are shown above in Figure 1.

Figure 2 - Floor Mat Kit # 100865



• Contents of floor mat kit 100865 are shown above in Figure 2.

INSTALLATION INSTRUCTIONS

1. Remove other floor mats from the vehicle before installing Minimizer floor mats.
2. Install the Minimizer floor mats right side up, with the Minimizer logo visible.
3. Each Minimizer floor mat is contoured to fit a particular location in the vehicle and may be used safely only in that location.

4. The Minimizer floor mat package contains one driver mat, one passenger mat and one center mat.

5. Test fit the center mat in between the seats of the truck. For some cab configurations hand trimming of the center mat is required. Figure 3 shows a diagram of the center mat with provisions for trimming. To trim the floor mat material, use a sharp utility knife. Use the raised ribbed areas shaded in yellow as a knife guide and preserve the raised rib for liquid containment.

• For trucks equipped with a floor mounted thermos holder or cup holder trim away the purple shaded area in Figure 3

• In day cab trucks it is common for the DOT roadside emergency kit to be mounted to the floor in between the driver and passenger seats. To accommodate the roadside emergency kit, (if present) the center mat is designed so the rear portion of the center mat can be trimmed off. This portion is shaded red in Figure 3 below.

Figure 3 - Center Mat Trimming Diagram

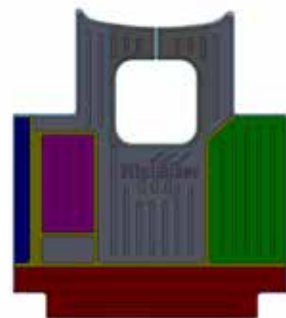

Figure 4 - Center Mat Trimming



• If the truck is equipped with an air ride driver seat with a rubber skirt around the base, as shown in Figure 5, the blue shaded portion (see Figure 3) of the center mat must be trimmed away for proper fit.

Figure 5 - Driver Seat with Rubber Skirt



• If the truck is equipped with a passenger seat with under seat battery storage as shown in Figure 6, the green shaded portion (see Figure 3) of the center mat must be trimmed in order for the center mat to fit.

Figure 6 - Passenger Seat with Under Seat Battery Storage



6. Test fit the driver mat in the truck. The driver mat is designed to fit underneath the throttle pedal. To install the driver mat, lift up the heel portion of the throttle pedal and slide the front of the floor mat underneath the pedal. Confirm that the mat is pushed all the way forward so it rests against the fire wall.

• In some cases trimming of the driver mat will be required. Figure 7 shows a diagram of the areas that have tall ribs built in to assist with trimming and liquid containment. Use a sharp utility knife to trim the floor mat material. Make sure to preserve the rib for liquid containment.

• If the truck is equipped with an air ride driver seat with a rubber skirt (see Figure 5) the green shaded area of the driver mat must be trimmed away for proper fit.

• If there is a fire extinguisher mounted between the driver door and the driver seat the blue

shaded area should be trimmed away to clear the fire extinguisher.

• Figure 8 below shows a properly trimmed driver mat installed next to an air ride driver seat with rubber skirt.

Figure 7 - Driver Mat Trimming Diagram

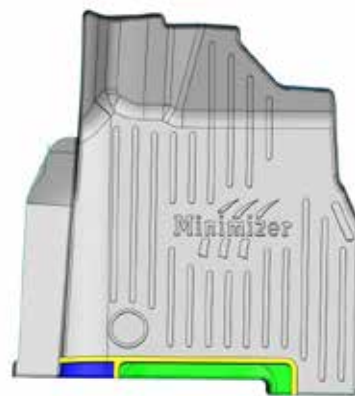

Figure 8 - Driver Mat Fit After Trimming



7. Inside the package with the installation instructions, locate two black plastic retention hooks as well as a white tube of Primer 94 as shown in Figure 9.

Figure 9 - Hook and Primer 94



8. Insert one hook through the hole at the right edge of the driver mat as shown in Figure 10. The hook should fit flush with the underside of the driver mat.

Figure 10 - Hook Inserted in Driver Mat



9. Once the hook is in place, let the driver mat and hook rest on the truck floor.

10. Mark the approximate position where the hook will be attached to the floor. Once the position is located, remove the driver mat from the truck.

11. Unpack the tube of Primer 94 and read the safety precautions printed on the tube and activate the tube of Primer 94 by crushing the tube at the black dot.

12. Clean all dirt or debris off the truck floor and apply Primer 94 to the floor area where the hook will be adhered.

13. Allow the Primer 94 to dry on the truck floor for five minutes.

14. Install the driver mat in the truck with the hook inserted. Next, peel away the paper backing from the hook.

15. While holding onto neck of the hook, lower the driver mat into position and stick the hook to the floor. Apply firm pressure to the hook for 30 seconds to ensure a proper bond to the rubber floor.

16. For optimal adhesion do not disturb the hook for a period of 20 minutes after installation. Figure 11 below shows the properly installed driver mat and hook.

Figure 11 - Driver Mat Hook Installation



17. Pull the driver mat toward the rear of the truck to confirm that the hook is fully engaged into the mat and that the hook is adhered to the floor. If the hook is not functioning properly or the mat cannot be securely installed, do not use a Minimizer floor mat on the driver side of the vehicle.

18. FAILURE TO PROPERLY INSTALL THE HOOK FOR THE DRIVER SIDE FLOOR MAT MAY ALLOW THE FLOOR MAT TO SHIFT, WHICH MAY INTERFERE WITH PROPER FUNCTIONING OF THE VEHICLE'S PEDALS, POTENTIALLY RESULTING IN LOSS OF CONTROL OF THE VEHICLE AND SERIOUS INJURY OR DEATH.

19. Move the accelerator, brake, and clutch pedals through their full range of motion to confirm there is no interference with the Minimizer floor mat.

20. Test fit the passenger floor mat in the truck. In some cases trimming of the passenger will be required. Figure 12 below shows a diagram of the areas that have tall ribs built in to assist with trimming and liquid containment.

Figure 12 - Passenger Mat Trimming Diagram

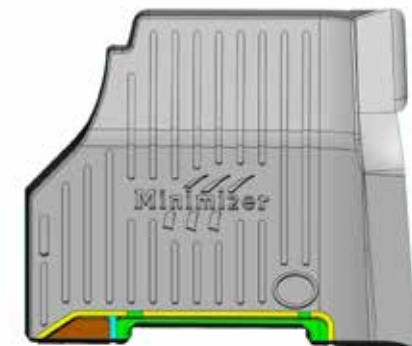

• If the truck is equipped with a passenger seat with under seat battery storage, the green, blue and brown shaded areas of the passenger mat must be trimmed in order for the passenger mat to fit.

• If the truck is equipped with an air ride passenger seat with a rubber skirt around the base, the green shaded areas of the center mat must be trimmed away for proper fit.

21. Install the passenger mat retention hook. Repeat steps 11-16 above to properly attach the hook to the floor of the truck.

22. Prior to operating the vehicle, read the Safety Instructions for Vehicle Operation.